

L max: 230 cm
H max: 300 cm

USE

UTILIZZO - USE - USO
USO - UTILISATION - ANWENDUNG
GEBRUIK - ИСПОЛЬЗОВАНИЕ

SISTEMA PER TENDE PLESETTATE CON PIEGHE DA 20 mm

Indicato per installazioni domestiche e professionali.

Scorrimento verticale, inclinato.

Indicato per tende filtranti e semioscuranti max 230x300 cm.

Azionamento con corde.

Arresto frontale a ghigliottina ultrapiatto.

L'installazione, preferibilmente su serramento o direttamente a soffitto, è con supporti a scatto che facilitano la rimozione del profilo.

PLEATED BLIND SYSTEM WITH 20 mm PLEATS

Suitable for domestic and professional installations.

Vertical and sloping sliding.

Suitable for filtering and semi-dimming blinds 230x300 cm max.

Cord operated.

Ultra-flat guillotine front stop.

Installation, preferably on the frame or directly on the ceiling, is by click supports that facilitate track removal.

SISTEMA DE CORTINAS PLISADAS CON PLIEGUES DE 20 mm

Indicado para instalaciones domésticas y profesionales.

Deslizamiento vertical o inclinado.

Indicado para cortinas filtrantes o semioscurecientes máx. 230 x 300 cm.

Accionamiento mediante cordones.

Parada frontal de guillotina ultraplano.

La instalación, preferiblemente en ventana o directamente en el techo, se efectúa con soportes a presión que facilitan el desmontaje del perfil.

SISTEMA PARA CORTINAS PLISSADAS COM PREGAS DE 20 mm

Indicado para instalações domésticas e profissionais.

Deslizamento vertical e inclinado. Indicado para cortinas filtrantes e de semi-escurecimento máx 230x300 cm.

Accionamento com cordões.

Paragem frontal de guilhotina ultra-plano.

A instalação, de preferência no caixilho ou directamente no tecto, é feita com suportes de pressão que facilitam a remoção do perfil.

SYSTÈME POUR RIDEAUX PLISSÉS AVEC PLIS DE 20 mm

Conseillés pour locaux domestiques et professionnels.

Coulissement vertical, incliné.

Indiqué pour rideaux filtrants et semi-occultants max 230x300 cm.

Actionnement par drisses.

Arrêt frontal à guillotine ultra-plat.

L'installation, de préférence sur croisée ou directement au plafond, est réalisée sur supports encliquetable qui facilitent le retrait du profil.

PLISSEE MIT 20 mm-FALTEN

Für den privaten Haushalt und den Arbeitsbereich.

Vertikale oder schräge Führung.

Für Blendschutzstoff und teilweise abdunkelnden Stoff geeignet max. 230x300 cm.

Schnurbetätigung.

Sehr flache Frontale Arretierung.

Befestigung mit Einrasthalterungen aus gehärtetem und vernickeltem Spannstahl.

Die Montage erfolgt vorzugsweise am Fenster oder direkt an der Decke mit Einrasthalterung, so dass das Profil leicht zu entfernen ist.

PLISSÉSYSTEEM MET 20 mm PLOOIBREEDTE

Voor privaat en professioneel gebruik.

Toepassing voor verticale en schuine ramen.

Gebruik met verduisterende en filterende stoffen max. 230 cm x 300 cm.

Extra plat Koordbediend. Frontale rem.

Plaatsing op het raam, of tegen de wand of het plafond.

СИСТЕМА ДЛЯ ПЛИССЕРОВАННЫХ ШТОР СО СКЛАДКАМИ 20 MM

Предназначена для установки в жилых и офисных помещениях.

Вертикальное и наклонное открытие.

Предназначена для фильтрующих и полузатемняющих штор макс. 230x300 см.

Приведение в действие кордом.

Ультра-плоский передний блокиратор корда

Боковой блокиратор корда с битенгом.

Установка, желательна на оконную раму или непосредственно на потолок, выполняется при помощи защелкивающихся суппортов, облегчающих демонтаж профиля.

**CARATTERISTICHE TECNICHE - SPECIFICATIONS
CARACTERÍSTICAS - CARACTERÍSTICAS - CARACTÉRISTIQUES
EIGENSCHAFTEN - KARAKTERISTIEKEN - ХАРАКТЕРИСТИКИ**

- Profilo superiore ed inferiore in lega d'alluminio estrusa 6060 T6-UNI 8278
 - Profilo superiore Larghezza 21 mm Altezza 14 mm
 - Profilo inferiore Larghezza 21 mm Altezza 11 mm
 - Profilo porta tessuto in ABS estruso
 - Finitura superficiale:
verniciatura poliester bianco RAL 9016 - nero RAL 9005 - vaniglia RAL 1013
 - Anodizzato argento, bronzo
 - Accessori in acetilica autolubrificante
 - Arresto in poliammide antiusura
-
- 6060 T6 UNI 8278 extruded aluminium alloy upper and lower track
 - Upper track: Width 21 mm; Height 14 mm
 - Lower track: Width 21 mm; Height 11 mm
 - Extruded ABS fabric holder track
 - Surface finish: RAL 9016 white - RAL 9005 black - RAL 1013 vanilla
 - Silver, bronze anodised
 - Self-lubricating acetylic accessories
 - Wearproof polyamide stop
-
- Perfil superior e inferior en aleación de aluminio extruido 6060 T6-UNI 8278
 - Perfil superior: Anchura 21 mm - Altura 14 mm
 - Perfil inferior: Anchura 21 mm - Altura 11 mm
 - Perfil portatejido en ABS extruido
 - Acabados de la superficie:
pintura poliéster blanca RAL 9016 - negra RAL 9005 - vainilla RAL 1013
 - Anodizado plata, bronce
 - Accesorios en acetálico autolubrificante
 - Freno de poliamida antiroce
-
- Perfis superior e inferior de liga de alumínio extrudido 6060 T6-UNI 8278
 - Perfis superior: Largura 21 mm; Altura 14 mm
 - Perfis inferior: Largura 21 mm; Altura 11 mm
 - Perfil porta-tecido em ABS extrudido
 - Acabamento superficial:
tinta de poliéster branca RAL 9016 - preta RAL 9005 vermelha RAL 1013
 - Anodizado prateado, bronze
 - Acessórios de resina acetálica autolubrificante
 - Batente de paragem de poliamida anti-desgaste
-
- Profil supérieur et inférieur en alliage d'aluminium extrudé 6060 T6-UNI 8278
 - Profil supérieur: Largeur 21 mm; Hauteur 14 mm
 - Profil inférieur: Largeur 21 mm; Hauteur 11 mm
 - Profil porte-tissu en ABS extrudé
 - Finition superficielle:
peinture polyester blanc RAL 9016 - noir RAL 9005 - vanille RAL 1013
 - Anodisé argent, bronze
 - Accessoires en résine d'acétal autolubrificante
 - Arrêt en polyamide anti-usure

**CARATTERISTICHE TECNICHE - SPECIFICATIONS
CARACTERÍSTICAS - CARACTERÍSTICAS - CARACTÉRISTIQUES
EIGENSCHAFTEN - KARAKTERISTIEKEN - ХАРАКТЕРИСТИКИ**

- Oberes und unteres Profil aus eloxiertem Aluminium 6060 T6-UNI 8278
 - Oberes Profil: Breite 21 mm; Höhe 14 mm
 - Unteres Profil: Breite 21 mm; Höhe 11 mm
 - Stoffhalteprofil aus extrudiertem ABS
 - Oberflächen-Finish:
Polyesterlackierung Weiß RAL 9016 - Schwarz RAL 9005 Vanille RAL 1013
 - Alu eloxiert, Bronze
 - Zubehör aus selbstschmierendem Acetal
 - Arretierung aus stoßfestem Polyamid
-
- 6060 T6 UNI 8278 aluminium boven- en onderprofiel
 - Bovenprofiel: Breedte 21 mm - hoogte 14 mm
 - Onderprofiel: Breedte 21 mm - hoogte 11 mm
 - ABS profiel voor de bevestiging van de stof
 - Oppervlaktebehandeling RAL 9016 wit - 9005 zwart - vanille RAL 1013 zilver en brons geanodiseerd
 - Zelfsmerende acetyl onderdelen
 - Polyamide eindstop
-
- Верхний и нижний профиль из экструдированного алюминия 6060 T6 UNI 8278
 - Ширина верхнего профиля 21 мм; Высота 14 мм
 - Ширина нижнего профиля 21 мм; Высота 11 мм
 - Несущий шторы профиль из экструдированного ПВХ
 - Отделка поверхности:
полиэфирная окраска в белый цвет RAL 9016 – черный цвет RAL 9005; ваниль - RAL 1013
 - Анодирование серебро - бронза
 - Аксессуары из самосмазывающейся ацеталовой пластмассы
 - Блокатор корда из износостойкого полиамида



APERTURA - OPENING - APERTURA - ABERTURA - OUVERTURE - AUFZUG - OPENEN - ОТКРЫТИЕ

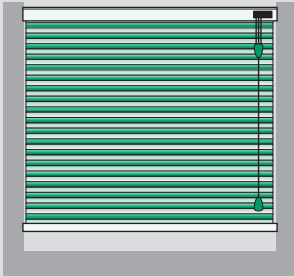

VERSIONE STANDARD
Standard Version

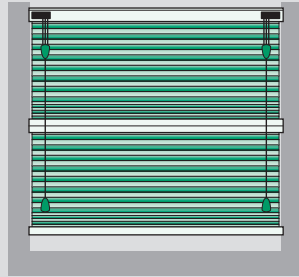

VERSIONE B
B Version

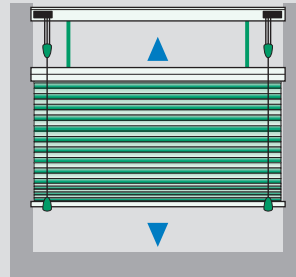

VERSIONE C
C Version

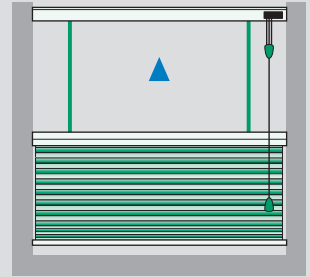

VERSIONE D
D Version

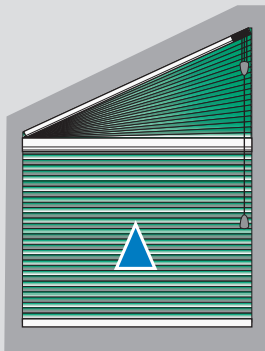

VERSIONE E
E Version

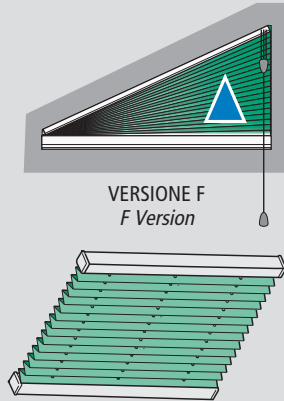

VERSIONE F
F Version

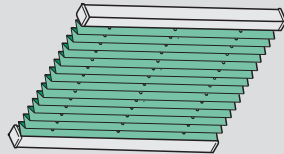

VERSIONE L
L Version

TENDE GUIDATE - GUIDED BLINDS - CORTINAS CON GUÍAS - CORTINAS COM GUIAS - PLISSÉ GUIDÉ - PLISSEE VERPANTT - PLISSE MET ZIJGELEIDING - ШТОРЫ С НАПРАВЛЯЮЩИМИ

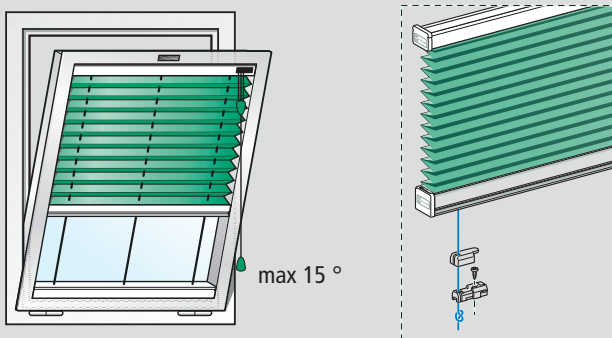

- Per l'applicazione su finestre inclinate e/o basculanti
- For use on raking and/or swinging window
- Para aplicacion en ventanas inclinadas o basculantes
- Para aplicação em janelas inclinadas e/ou basculantes
- Pour l'utilisation sur chassis ouvrants
- Für Dachschrägen und Kipfenster
- Voor gebruik op kantelende ramen
- Для установки на наклонных или качающихся окнах

INGOMBRI - OVERALL DIMENSIONS - ESPORES - DIMENSÃO - ENCOMBREMENT - RAUMBEDARF - ПАККЕТ - ГАБАРИТЫ

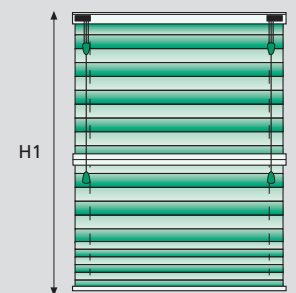
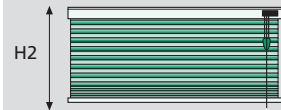
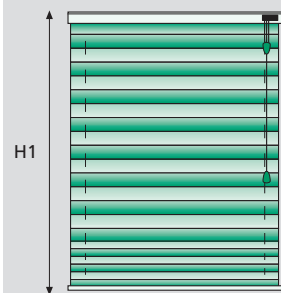

L max 230 cm
H1 max 300 cm
L min 15 cm
H2 min 30 cm

L max 150 cm
H1 max 300 cm
L min 15 cm
H2 min 30 cm

H1	H2
50 cm	≈ 5 cm
100 cm	≈ 6 cm
150 cm	≈ 7 cm
200 cm	≈ 8 cm
250 cm	≈ 9 cm
300 cm	≈ 10 cm

H1	H2
50 cm	≈ 9 cm
100 cm	≈ 11 cm
150 cm	≈ 13 cm
200 cm	≈ 15 cm
250 cm	≈ 17 cm
300 cm	≈ 19 cm

INSTALLAZIONE - INSTALLATION - INSTALCIÓN - INSTALAÇÃO - INSTALLATION - INSTALLATION - INSTALLATIE - УСТАНОВКА

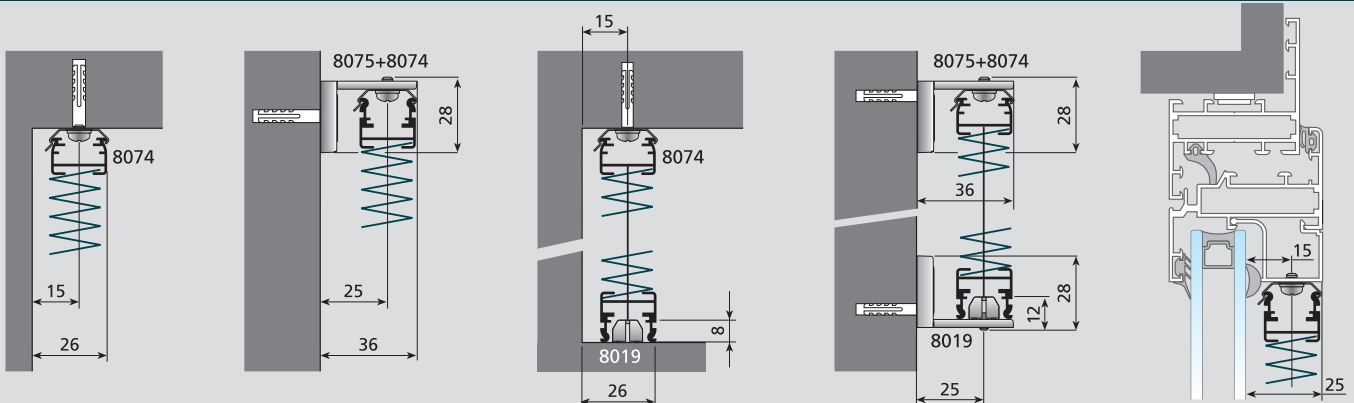



Plì_353/1

